



“SR” and “FR” Intelligent Battery Power System (IBPS)

Quick Start Guide for 2nd Generation
IBPS Modules
Rev 1.6 July 2010

Intelligent Battery Power System (IBPS)

- The IBPS Quick Start Guide is provided to assist new users with basic interconnect procedures and to answer most of the commonly asked set-up questions.
- The IBPS can manage all aspects of powering a system with battery power
 - charges batteries using almost any external power source from power supplies to solar panels
 - switches power to load between external power and battery power
 - can simultaneously power system and charge batteries
- Fully configurable to meet specific needs of your system
- The difference between the “SR” and “FR” variants is just the PCB size. “R” indicates the product is RoHS Compliant.

- Power Small systems (1-4 batteries):
 - managing power for small portable systems
 - provide UPS battery backup
- Power Medium systems (4-8 batteries):
 - manage power for larger portable systems
 - provide UPS battery backup for larger systems
- Power Large systems (8+ batteries):
 - allow the ability to manage 100+ batteries to create “portable” systems with over 12,000 Watt-hours of power
 - Class 9 Hazardous Goods regulations do not apply due to battery size

BB-04SR / MP-04SR / XP-04SR/ MP-08SR/ XP-08S Base Battery Management Module

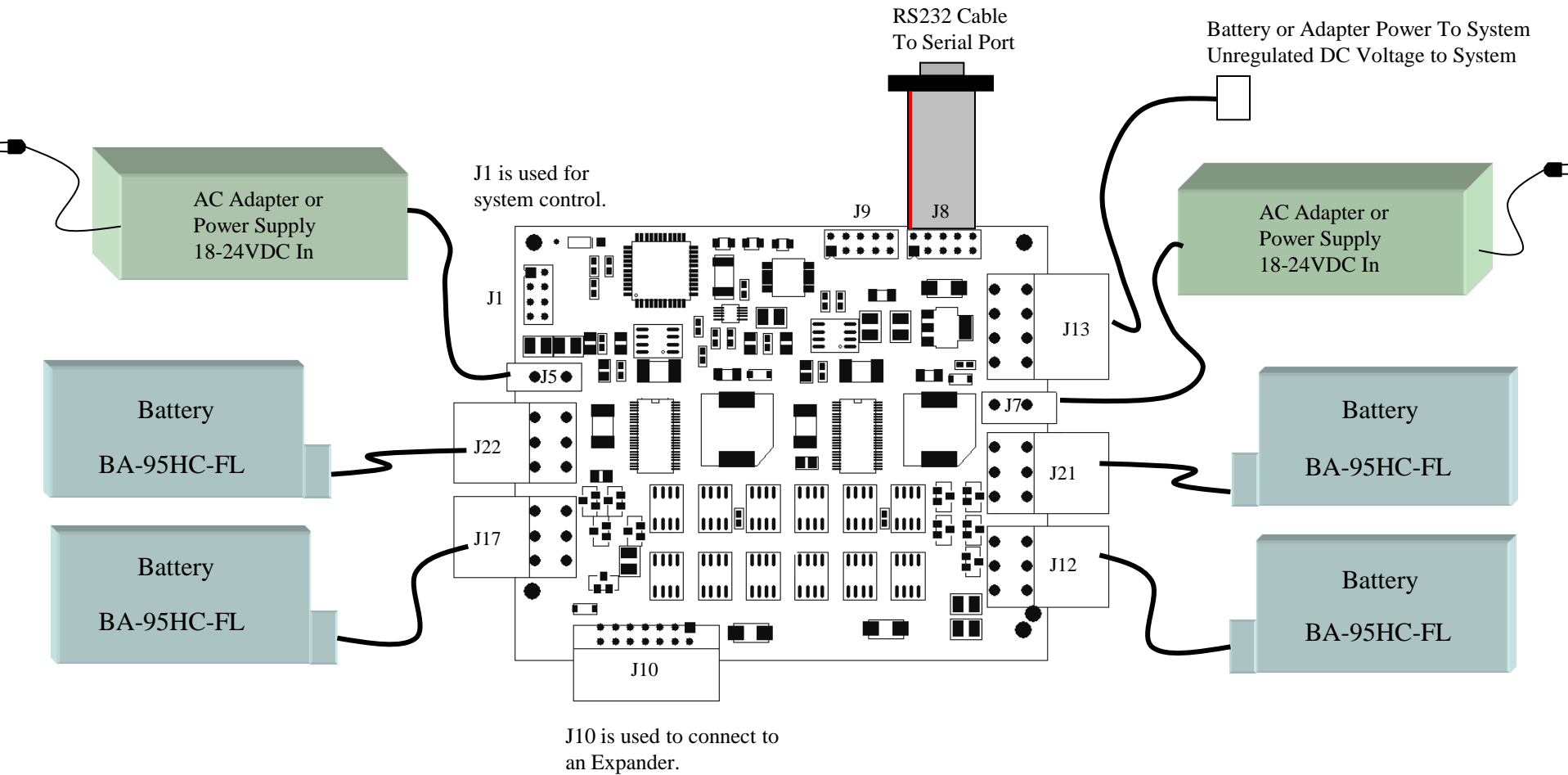

BB-04SR / MP-04SR / XP-04SR/ MP-08SR/
XP-08S Base Battery Management Module

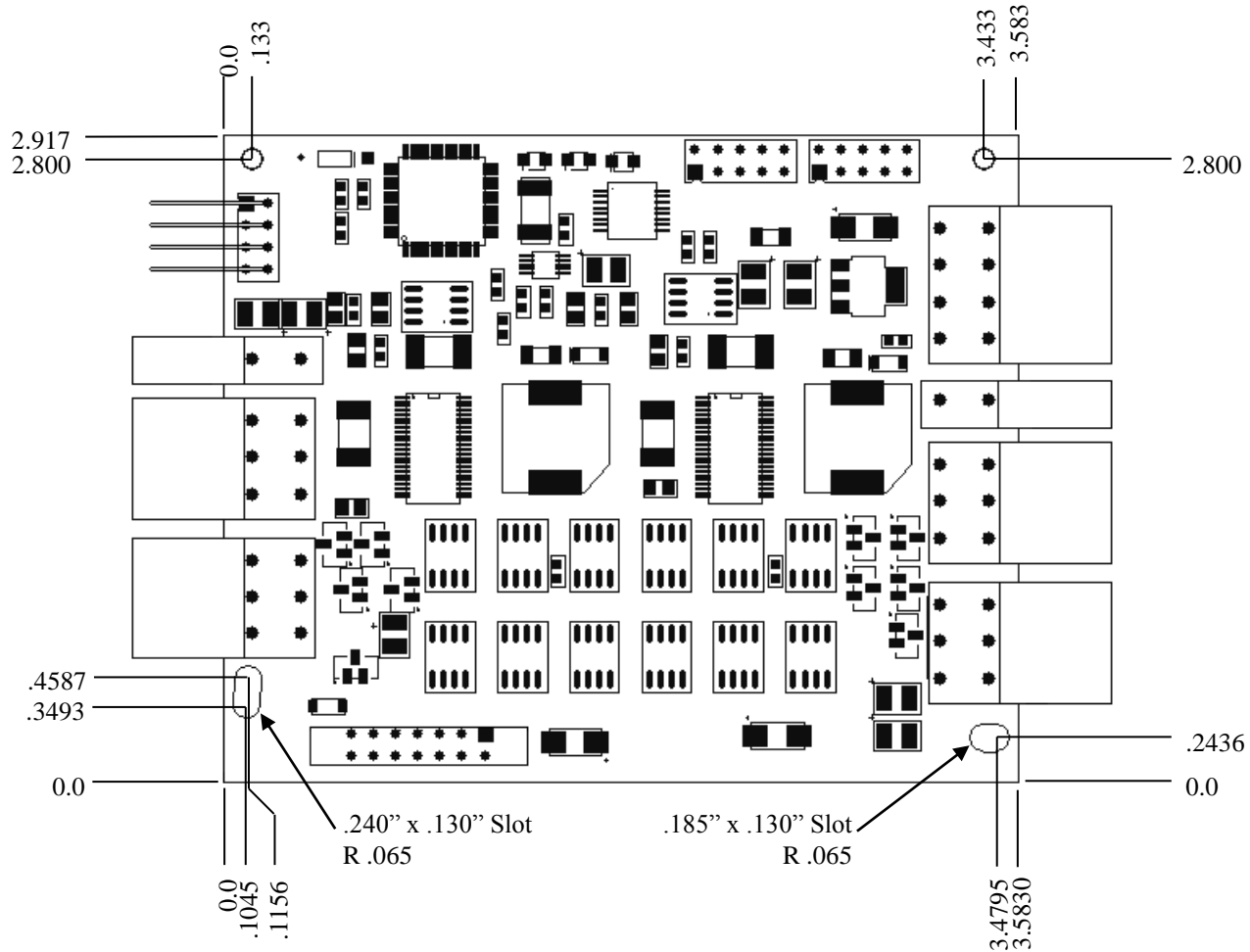

**BB-04FR / MP-04FR/XP-04FR / MP-08FR/
XP-08FR Base Battery Management Module**

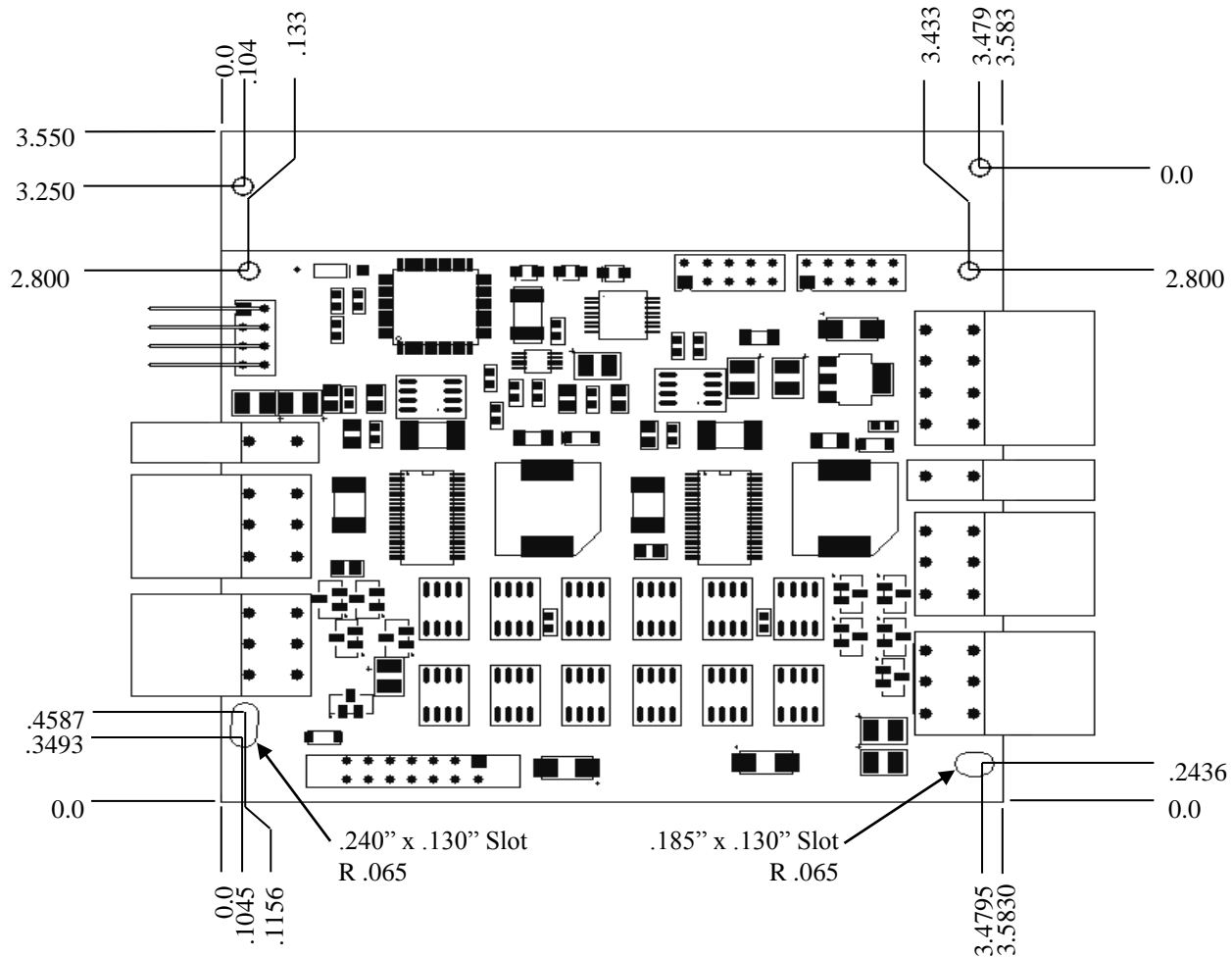

BB-04FR / MP-04FR/XP-04FR / MP-08FR/ XP-08FR PC104 Mounting

This diagram shows a comparison between an “FR” module vs. a standard PC/104 module.

The blue outline and dimensions correlate to a standard PC/104 module.

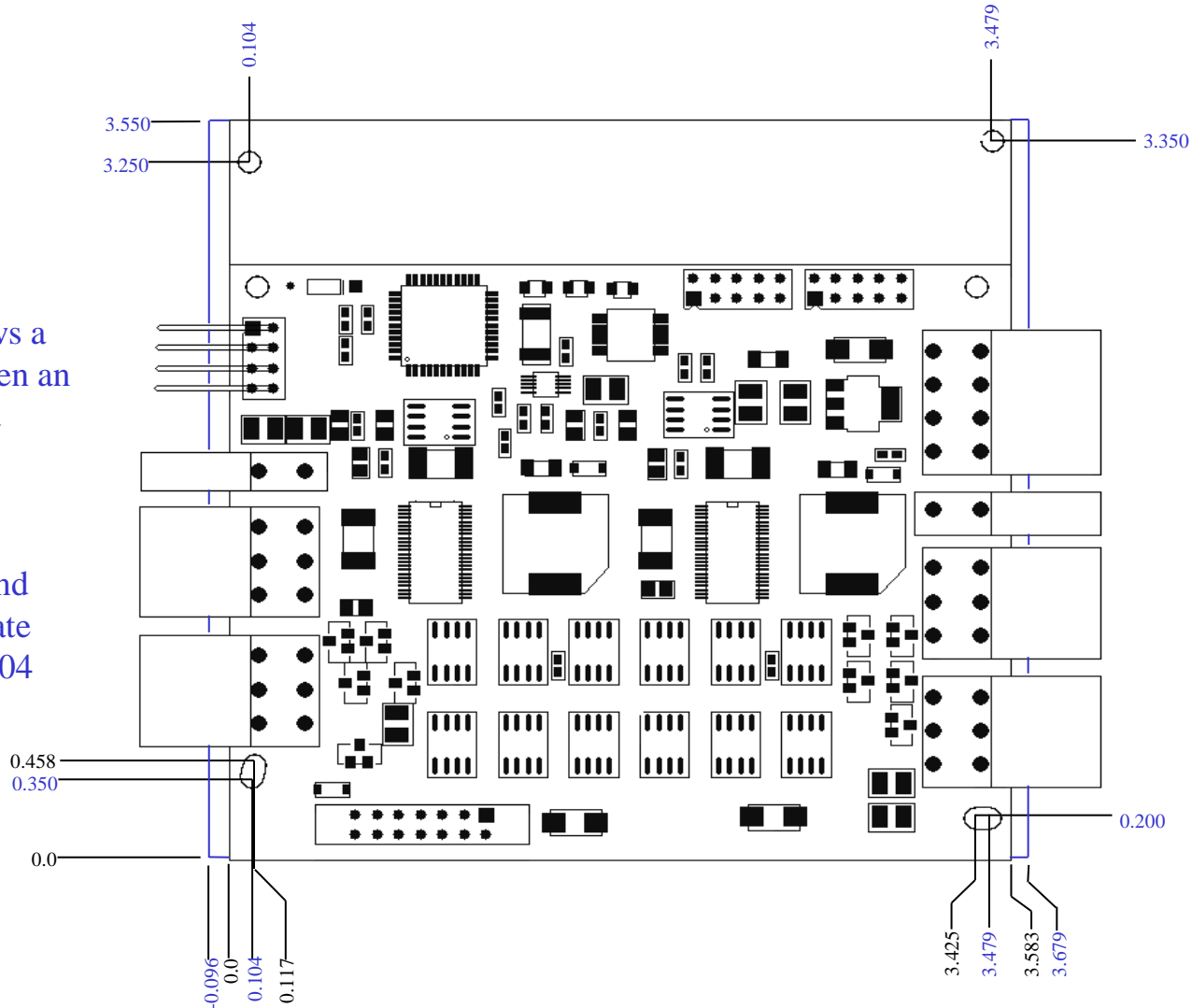

BB-04SR / MP-04SR / XP-04SR/ MP-08SR/ XP-08S Base Battery Management Module

J1 is used for system control.

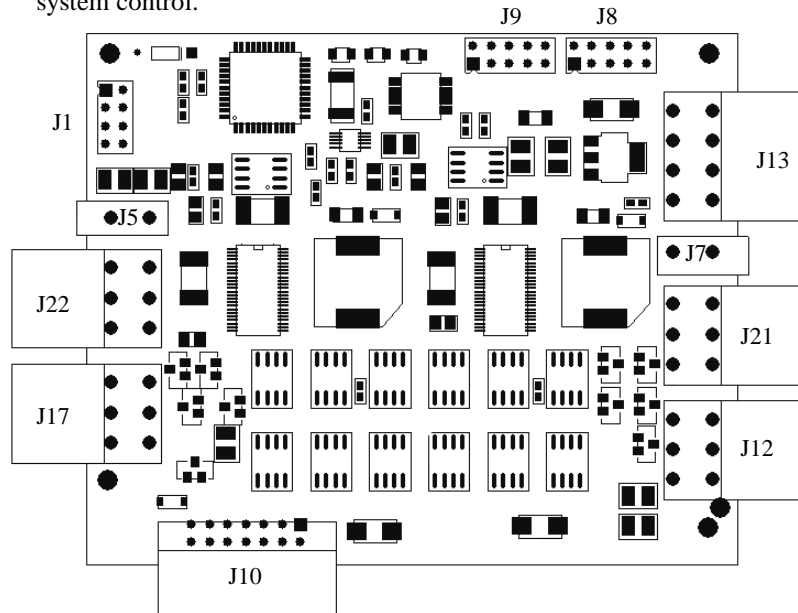
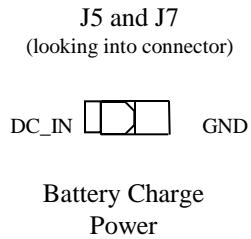

J10 is used to connect to an Expander.

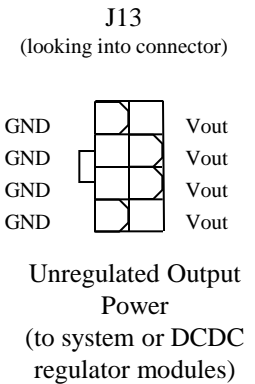

Standard IBPS battery controllers vs. The “SR” and “FR” versions

- The “SR” version is has a smaller form factor, 2.917” x 3.583” vs 3.55” x 3.775”.
- The “SR” and “FR” versions can handle more DC_IN current to system, 12A vs 6A.
- The “SR” and “FR” versions allows for more current to the system while still supplying charge power to the batteries.

B-04SR / MP-04SR / XP-04SR/ MP-08SR/ XP-08SR Comparison

- The BB-04SR supports 1-4 batteries with a current load of 13.25A max
- The MP-04SR supports 1-4 batteries with a current load of 20A max and also supports multiple Battery Clusters™.
- The XP-04SR supports 1-4 batteries with a current load of 26.5A max and also supports multiple Battery Clusters™
- The MP-08SR supports 1-8 batteries with a current load of 40A max and also supports multiple Battery Clusters™.
- The XP-08SR supports 1-8 batteries with a current load of 53.25A max and also supports multiple Battery Clusters™.

External Power

- AC adapters or power supplies can be connected to J5 and J7. An external power source is not needed, but if attached, the power can be used to run the system and to charge the batteries (if needed).
- Power connected to J7 will be used to charge batteries 1 and 2.
- Power connected to J5 will be used to charge batteries 3 and 4.
- Power connected to J5 and J7 can be used to power the main system.
- One power supply can be connected to both J5 and J7 if it can supply enough power to meet the system's needs.
- The AC adapter or power supply should provide between 18-24 Volts.

External Power cont...

- 12 Amps of power can be delivered to the system through J5 and 12 Amps can be delivered to the system through J7. This allows for a total of 24 Amps to be supplied to the system from external power.
- Up to 4 Amps of power will be supplied to each pair of batteries for charging (if necessary).
- The PS-70 is a 70W, (18V @ 3.9A) power supply with a 2.5/5.5mm barrel connector. Use cable 19-00003-12 to connect to the controller.
- The PS-100 is a 100W, (18V @ 5.56A) power supply with a 2.5/5.5mm barrel connector. Use cable 19-00003-12 to connect to the controller.
- The PS-320 is a 320W, (20V @ 10.5A) power supply. This supply is recommended for MP-08 systems. Use cable 19-00020-24 (1 per battery pair) to connect to the controller.
- The PS-600 is a 600W, (18V @ 33A) power supply. This supply can be connected in parallel for large battery systems. Use cable 19-00020-24 (1 per battery pair) to connect to the controller. AC into the PS-600 can be either 110 or 220 VAC, selectable via a slide switch on the case.

Batteries

- Up to 4 Smart Battery Packs can be connected directly to the Base Battery Management Module. Battery 1 is connected to J12. Battery 2 is connected to J21. Battery 3 is connected to J17. Battery 4 is connected to J22.
- The controller will autonomously handle and monitor all aspects of the battery behavior, switching them into the circuit to supply power to the system and charging them when needed.
- The BA-95HC-FL is a 14.4V, 6.6Ah, 8Amp max discharge rate, 95Wh battery with an ~10” flying lead connector that attaches directly to the controller. The dimensions are ~6.25” x 4.30” x 0.84”.
- The BA-95HCL-FL is a 14.4V, 6.6Ah, 8Amp max discharge rate, 95Wh battery with an ~10” flying lead connector that attaches directly to the controller. The dimensions are ~11.0” x 2.4” x 0.84”. This slimmer form factor may allow more batteries to fit into a tighter space.
- A 6” extension cable (19-00035-06) is available if cables need to be longer than 10”.

Batteries cont...

- The BA-95 is a 14.4V, 6.6Ah, 95Wh battery that attaches through a backplane. This allows for installation and removal similar to laptops. An external cable is routed from the backplane directly to J12, J17, J21, or J22. The dimensions are ~6.25" x 4.30" x 0.84".
- The BA-95HC is a 14.4V, 6.6Ah, 8Amp max discharge rate, 95Wh battery that attaches through a backplane. This allows for installation and removal similar to laptops. An external cable is routed from the backplane directly to J12, J17, J21, or J22. The dimensions are ~6.25" x 4.30" x 0.84.
- See the IBPS User Guide for more information about attaching batteries through backplanes.

- Raw battery power or power from the external power source is connected through the IBPS to your system through J13 (cable 19-00004-24).
- The Base Battery Management Module will handle all aspects of power to your system.
- The Base Battery Management Module will monitor all power inputs and connect the appropriate power source to your system. The controller will automatically switch the power being supplied to the system from the batteries to the external power when an external power source is connected. Any remaining power capacity from the external power supply will be used to charge the batteries (if necessary).
- The power switching happens fast enough so the system experiences no interruption in power.

Connecting to a Host System

- The Base Battery Management Module can be connected to a PC or other system through an RS232 serial port when connected to J8 through OceanServer's serial port conversion cable (19-00010-00). The conversion cable connects to J8 and has a male DB9 style connector to connect to a standard serial cable (19-00011-00).
- Connecting the Base Battery Management Module to a host system allows users to monitor the battery/power system and to set up and configure advanced features of the IBPS Power System.
- MINIBATS™ is a Windows-based software program that allows laptop style power monitoring. With MINIBATS™ you can configure the system to automatically run a program and cleanly shutdown the system when the battery power reaches programmed settings.
- FULLBATS™ is a Windows-based software program that provides advanced detailed status of the battery powered system. This is a very powerful tool used for monitoring and logging power information for systems with multiple controllers.
- A Hyperterminal can also be used to connect directly to the controller to monitor status and to customize the behavior of the controller. Some of the items that can be configured are power on and power down policies, display options, and configuration parameters.
- See The IBPS Software User Guide for more details.

RS232 Port to DB9 Cable

- Pin
- 1 – tied to pins 2 and 7
 - 2 – tied to pins 1 and 7
 - 3 – TX_OUT
 - 4 – tied to pin 6
 - 5 – RX_IN
 - 6 – tied to pin 4
 - 7 – tied to pins 1 and 2
 - 8 – no connect
 - 9 – Ground
 - 10 – +5V

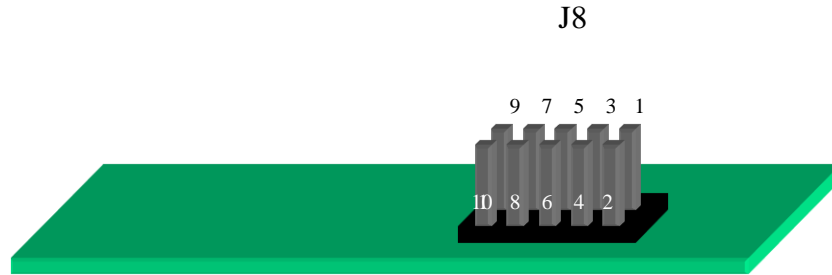

DTK Standard Com Port
Motherboard pin out

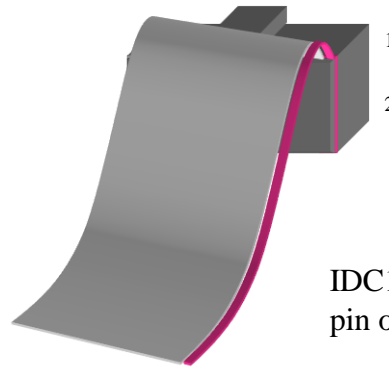

IDC10 to DB9M Serial Cable – DTK
pin out (19-00010-00)

To Host Serial Cable – DB9F to DB9F, 1:1 wiring
(19-00011-00)

External Control

- J1 is used for external control of the Base Battery Management Module.
- A 2 pin header connector attached to a switch (cable 19-00027-00) and connected to pins 2 and 4 can be used to turn the Base and DC-123SR, DC-DC Converter Module, on and off. Three switch types are supported, a toggle switch, a momentary pushbutton switch, and a PC style momentary switch. When configured as a PC style switch, momentarily pushing the switch will turn the system on and when held for 3 seconds, it turns the system off.
- A 2 pin header connector attached to pins 6 and 8 will provide a TTL output that can be used for external control. The output can be configured to be high when the system is turned on and will go low when the external system needs to be turned off. The parameters of this output can be configured through the RS232 port.
- A 2 pin header connected to pins 1 and 2 can be used to control an external LED to monitor the percent of charge in the battery system when the system is discharging. The LED will blink about once a second and the ratio of the time on vs. the time off will indicate the percent of charge left on the batteries. Always on will indicate fully charged.

External Control cont...

- A 2 pin header connected to pins 7 and 8 can be used to control an external LED to monitor the percent of charge in the battery system when the system is charging. The LED will blink about once a second and the ratio of the time on vs. the time off will indicate the percent of charge on the batteries. Always on will indicate fully charged.
- An external LCD display (LCD16x2) can be attached to the controller on pins 3, 5, and 8. This will allow for more detailed information to be displayed without the need of a host system.
- The LCD display contains two lines of information. One line is used for a bar graph displaying the amount of charge left in the battery system. The bar graph also indicates if the battery is charging or discharging.
- The second line of the LCD display can show the power consumption and the current entering or leaving the battery subsystem. The second line of the display can also show the time to fully charged when charging the batteries or the time to fully discharge the batteries when power to the system is being supplied by the batteries.
- The second line of the display is configurable and can be set up to show all or none of the data mentioned above. See The IBPS Software Users Guide for more information. The LCD display supports backlighting when an additional 5V connection is made (J8 pin 10). See User Guide for more information.

External Control and Status Connections

- Pin
- 1 – Green LED
 - 2 – Ground
 - 3 – LCD data
 - 4 – External On/Off switch (weak pull-up to 5V input)
 - 5 – 5V (20mA max.)
 - 6 - Shutdown signal (TTL), turn off DC-DC or Load
 - 7 – Yellow LED
 - 8 - Ground

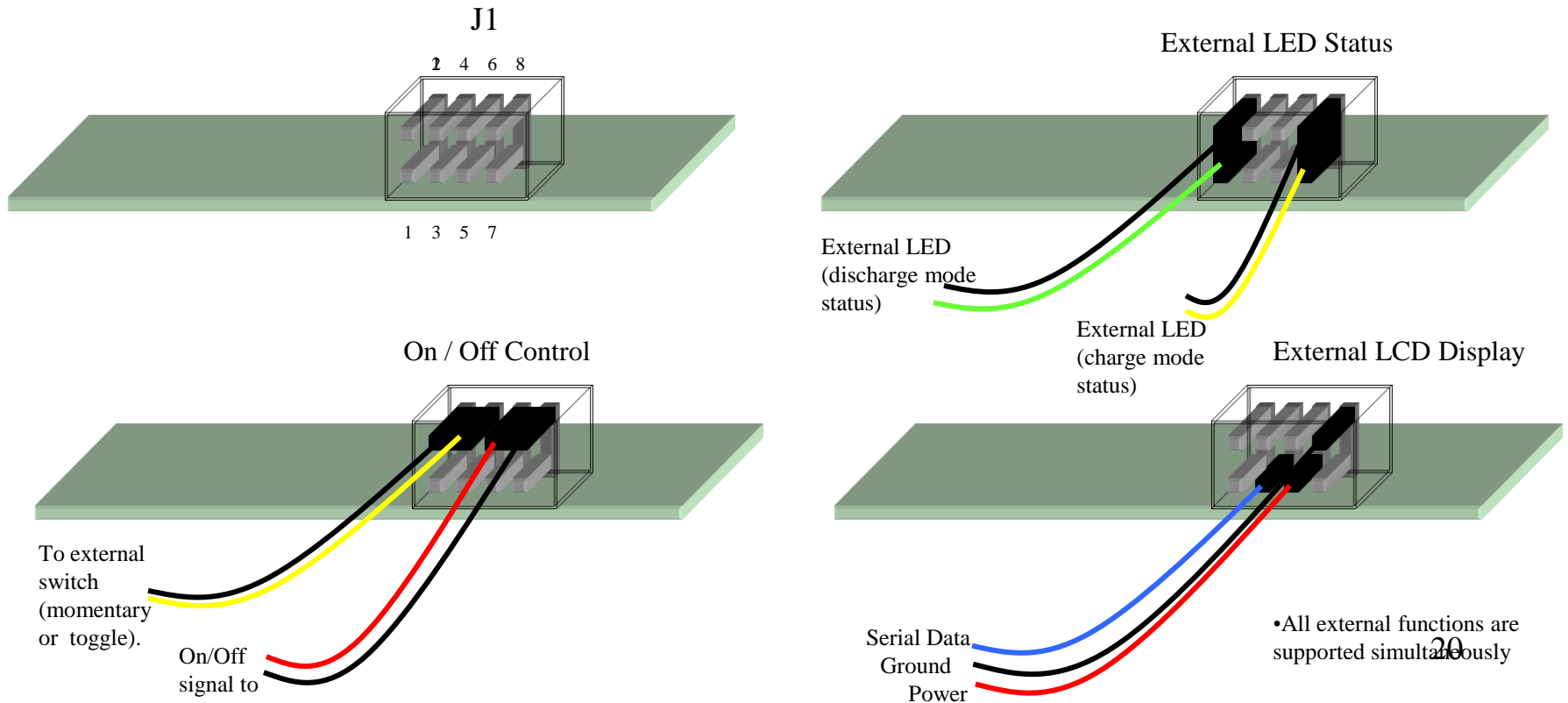

External Control / Status Cable

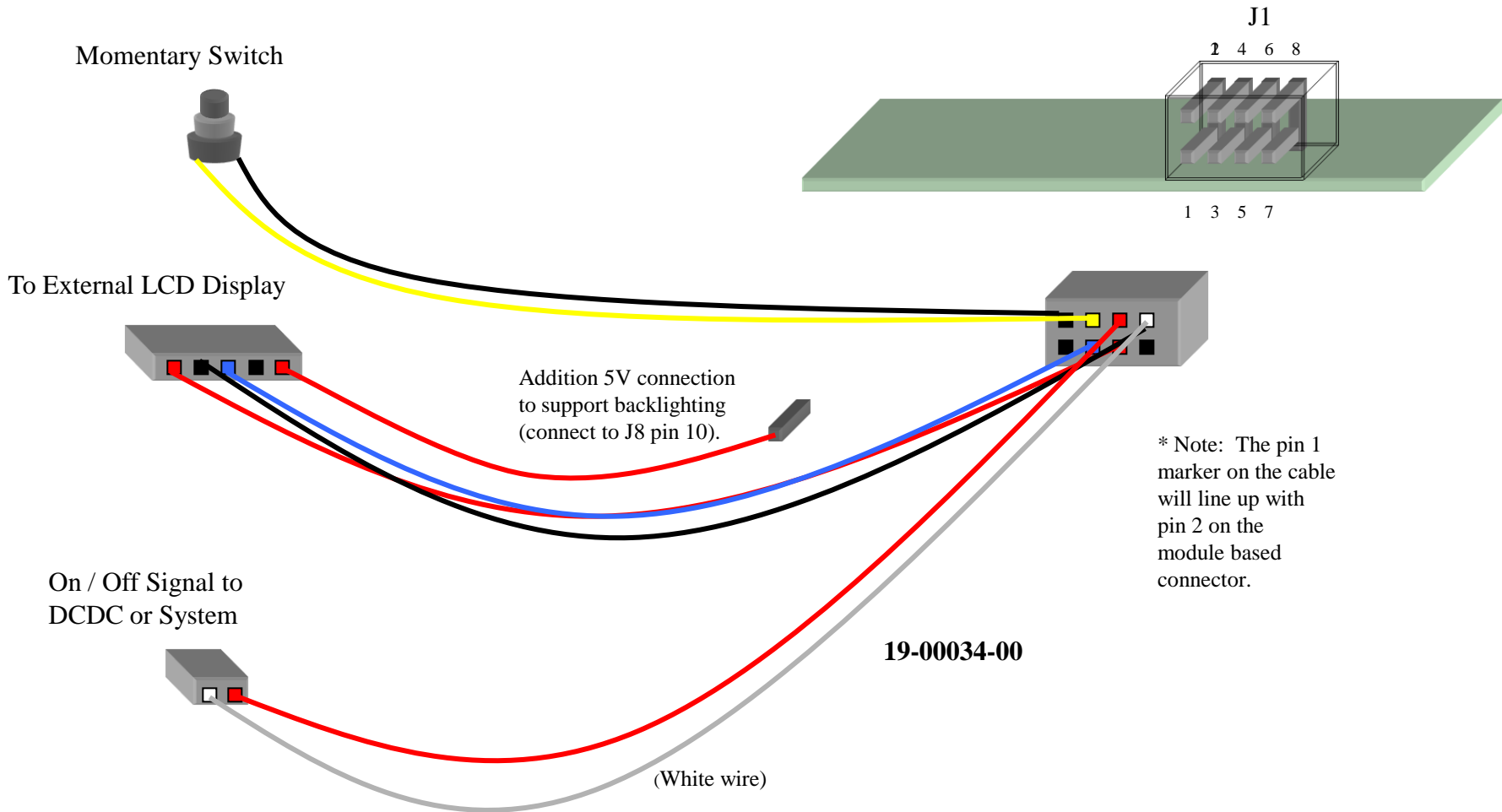

External LCD Display

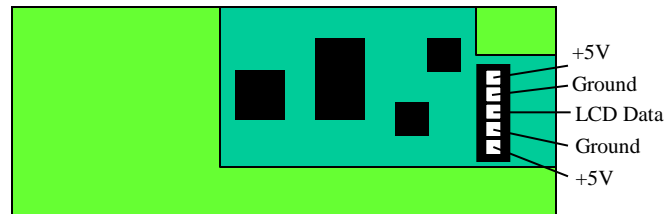
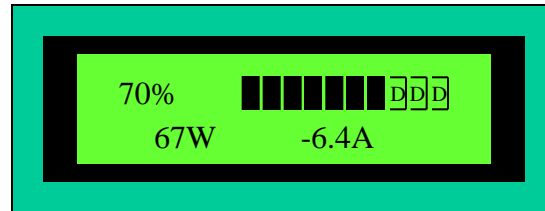

Side 2

Expansion Module Port

The expansion cable for a battery controller with a battery expansion module or a DC-123SR is a 19-00045-03.

The expansion cable for a battery controller with a battery expansion module and a DC-123SR is a 19-00053-00 (see page 30 for stacking modules).

The cable is a 1 to 1 connection between the two modules and should be no longer than 6"

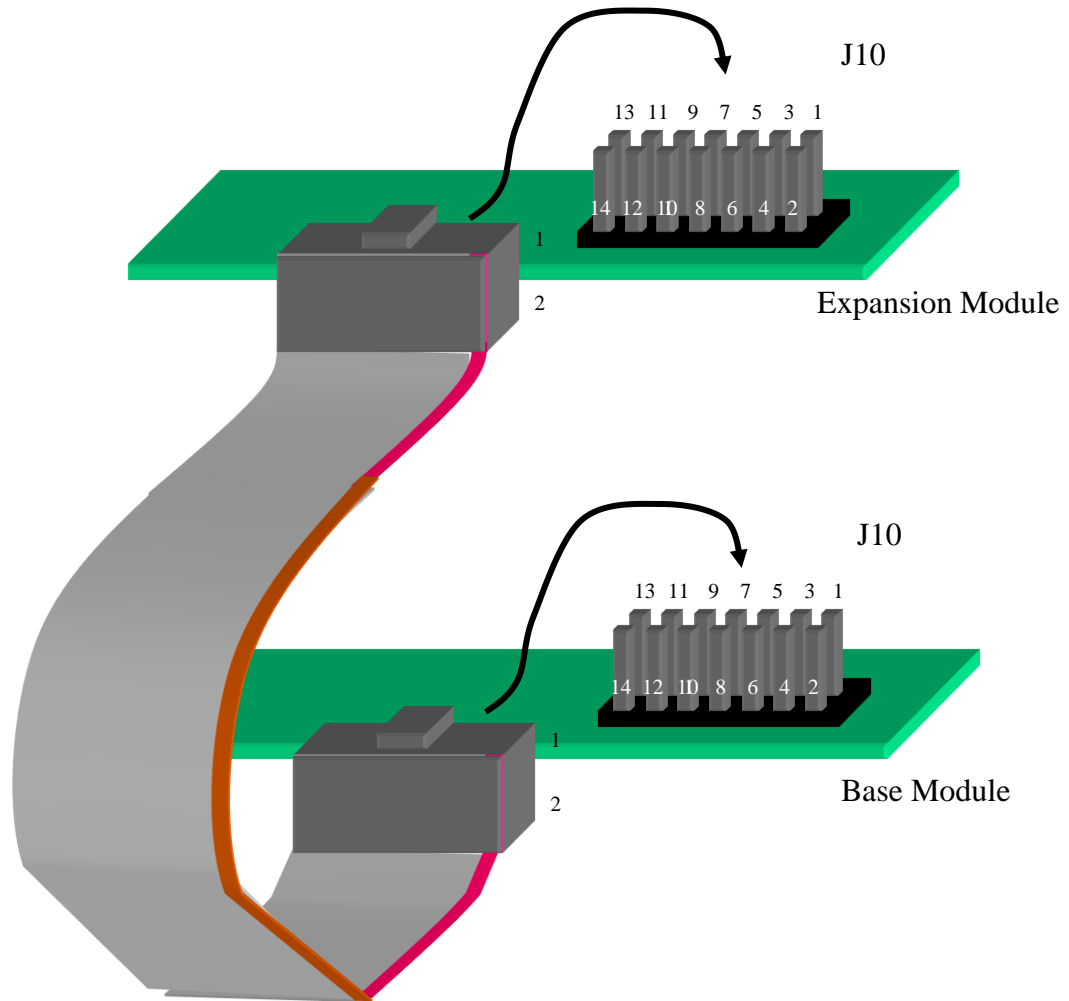

Expansion Module MP-08SR System

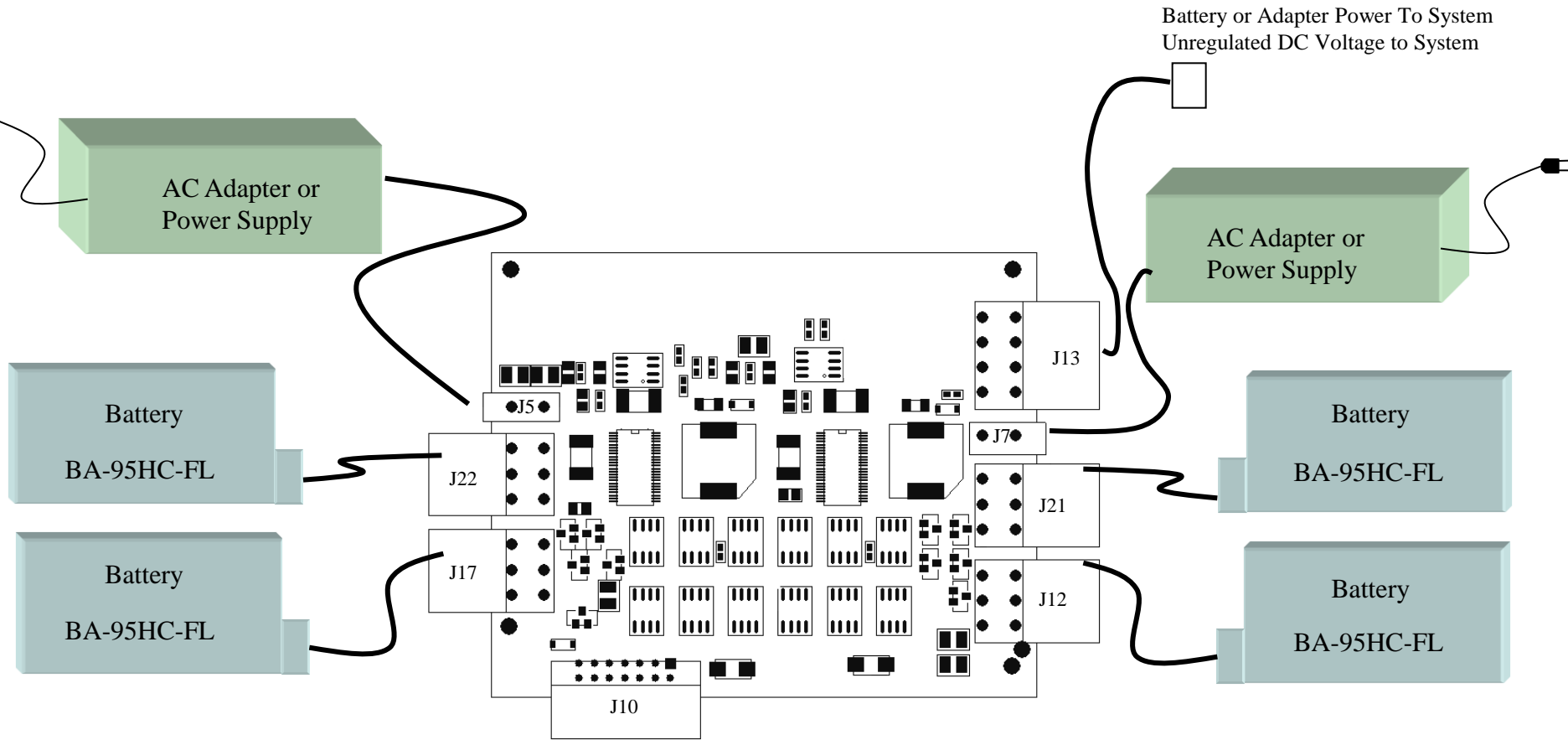

J10 is used to connect to an Expander.

- The Expansion Module allows up to four more batteries to be attached to the IBPS for a total of 8 batteries, thus forming an MP-08SR or XP-08SR System.
- The connections to the Expansion Module have the same properties as the Base Battery Management Module.
- Up to 4 Smart Battery Packs can be connected directly to the Expansion Module. Battery 5 is connected to J12. Battery 6 is connected to J21. Battery 7 is connected to J17. Battery 8 is connected to J22.
- AC adapters or power supplies can be connected to J5 and J7. The power can be used to run the system and to charge the batteries (if needed).
- Power connected to J7 will be used to charge batteries 5 and 6.
- Power connected to J5 will be used to charge batteries 7 and 8.
- At least one power source (battery or power supply) must be connected to the Base Battery Management Module for the MP-08SR/XP-08SR to function.

DC-123SR DC-DC Converter Module

J6
(looking into connector)

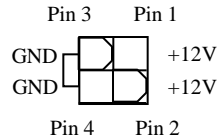

Auxiliary +12V power connector

J20
(looking into connector)

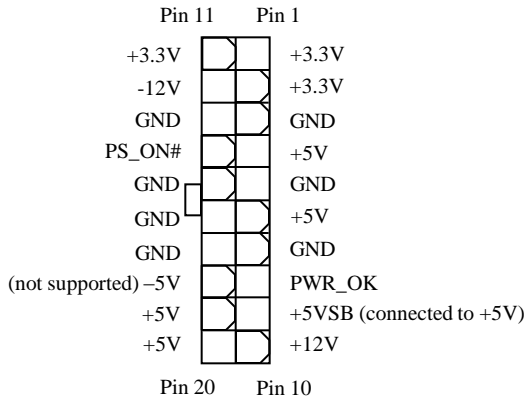

Standard ATX style power connector

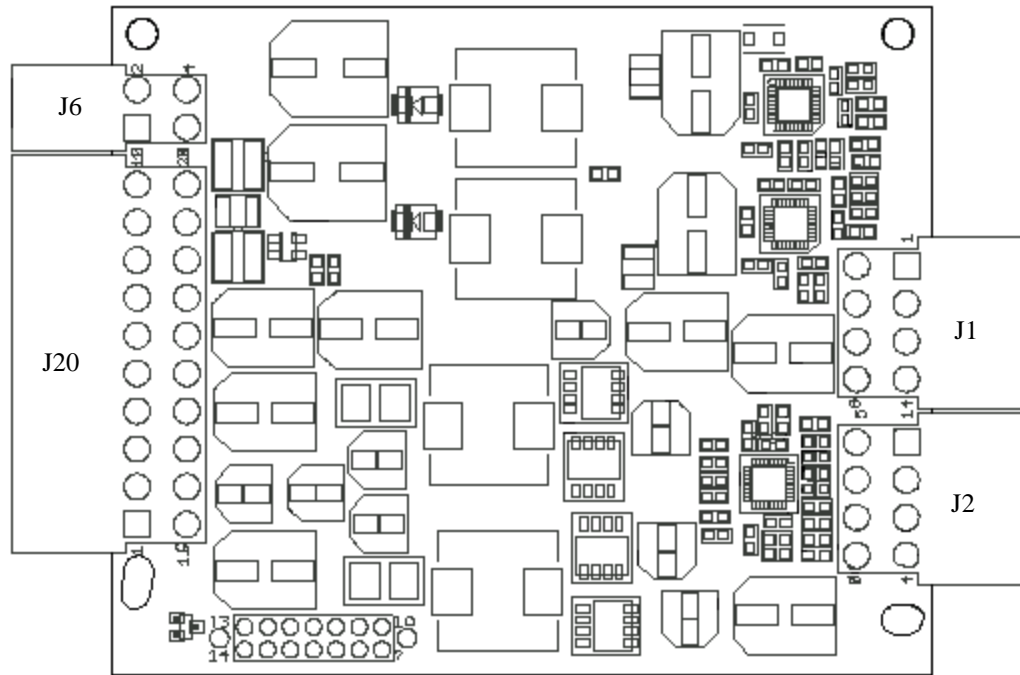

J10
Expansion Module
Connector

J1- J2
(looking into connector)

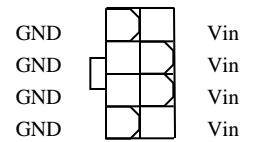

Unregulated Input
Power
(from base battery
and expander
Modules J13)

DC-123SR DC-DC Module

- The DC-123SR DC-DC Converter Module will convert the power supplied by the batteries or an external power source to 3.3V, 5V, 12V, and -12V. The module supports an ATX style power connector to allow users to directly connect to a PC motherboard or any other device. The system is now portable or battery backed up.
- It provides up to 10A of 3.3V, 10A of 5V, 12A of 12V and 300mA of -12V.
- J1 and J2 supplies the power to run the DC-DC converters.
- J10 provides the control signals for turning the regulators on and off.
- J6 is a 4 pin connector that provides an additional +12V connection and can be connected to your system.

DC-123SR DC-DC Module cont...

- J20 is an ATX style power connector. This can be hooked directly up to a PC motherboard or system that supports an ATX style connection (cable 19-00014-00).
- Stand-by Power is not supported. The current required to support this feature can be considerable over time for a system powered by batteries. +5V is supplied to the 5VSB pin when power is turned on.
- Please note the DC-123SR mounts to both the “SR” and “FR” version boards

DC-123SR DC-DC Module cont...

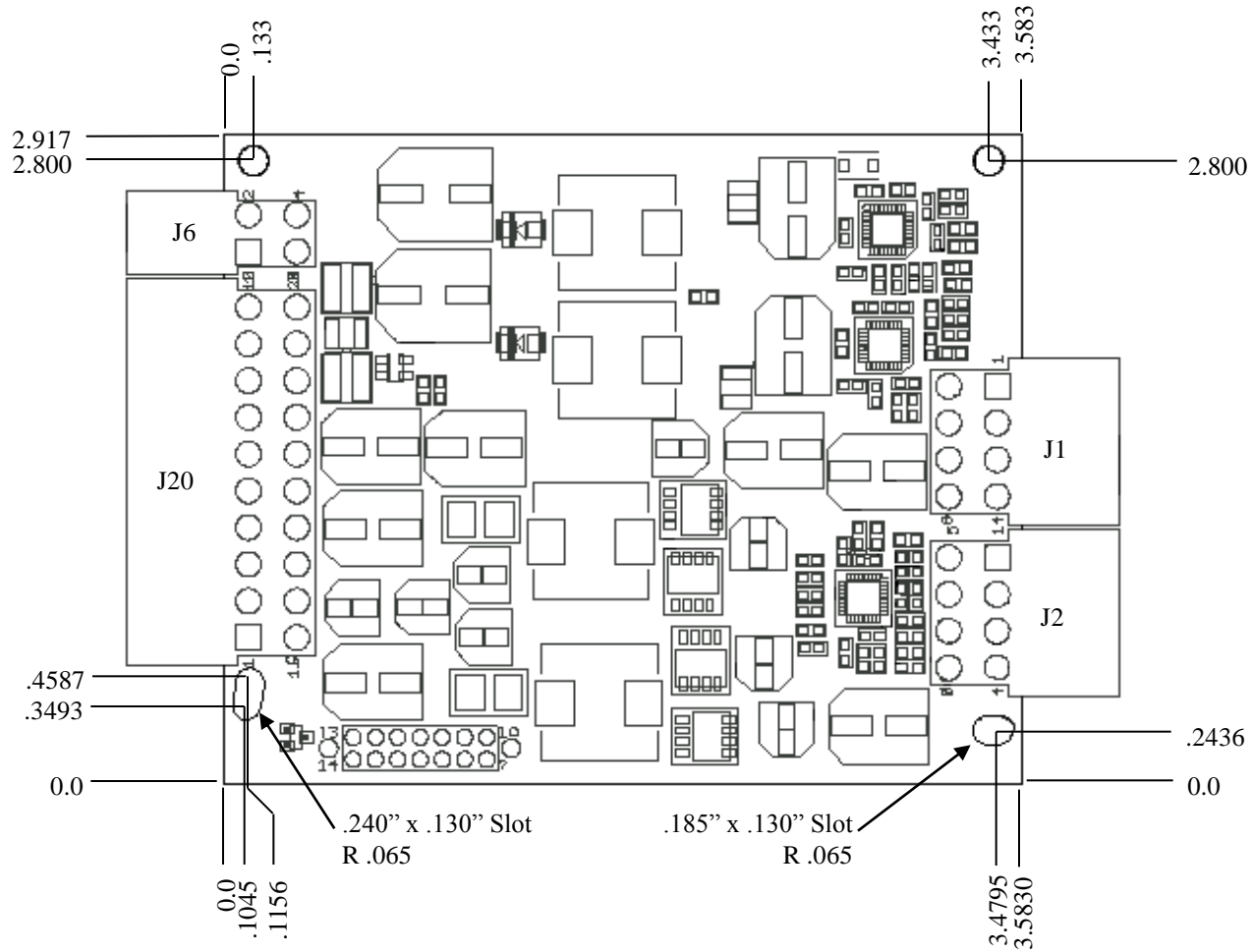

Stacking Multiple Modules

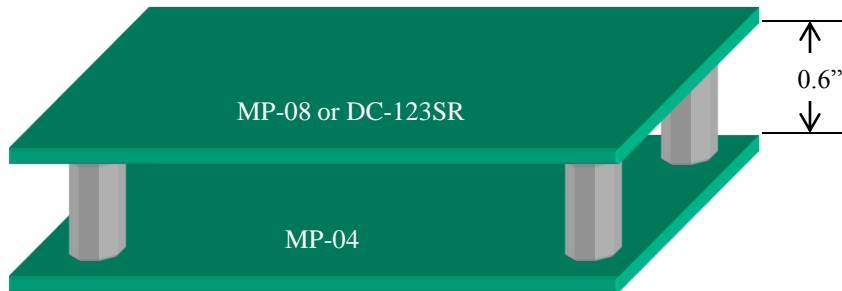

Two high stack

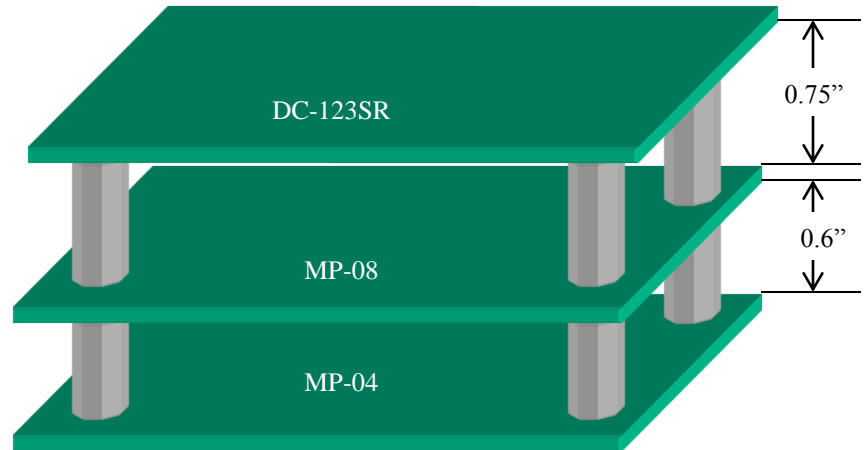

Three high stack

Note: The third module in the stack needs to be spaced slightly higher than 0.6" to allow for the routing of the ribbon cable connected to the expansion connector.

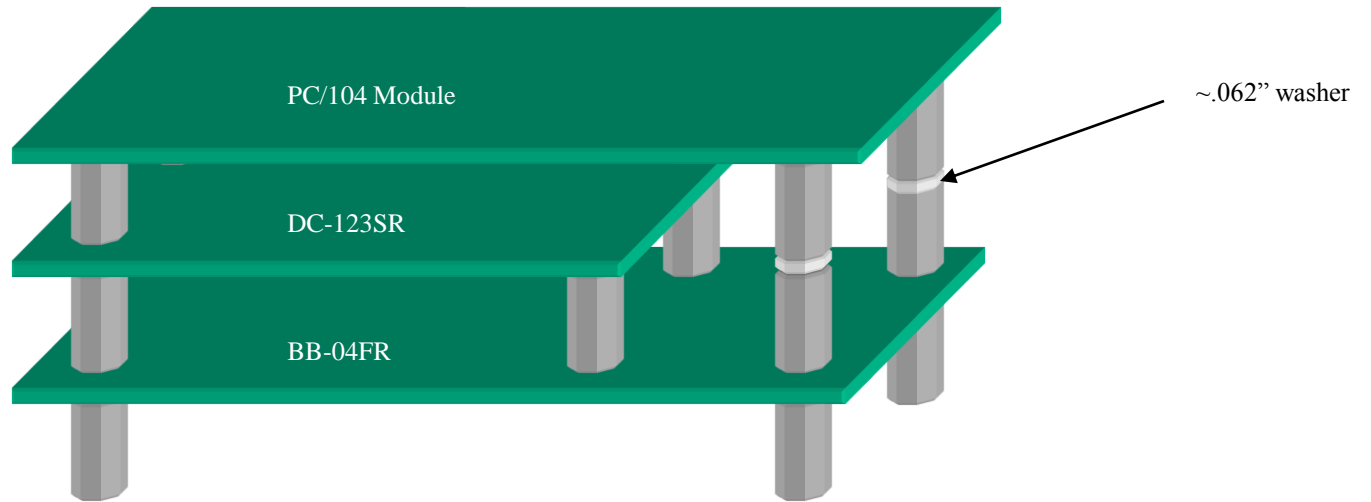



Customer Support

Send technical questions to: support@ocean-server.com

Or call us at 508-678-0550 during normal business hours.

Related Publications:

Please visit our download page and download our latest IBPS Hardware and Software User Guides and FAQs guide.

<http://www.ocean-server.com/download.html>

Copyright © 2010 by OceanServer Technology, Inc. All rights reserved.